

**PHILIPS  
ADVANCE**

**Metal  
Halide  
Lamp Ballast**

**Catalog Number 71A5741  
For 250W M58  
60 Hz CWA  
Status: Active**

**DIMENSIONS AND DATA**

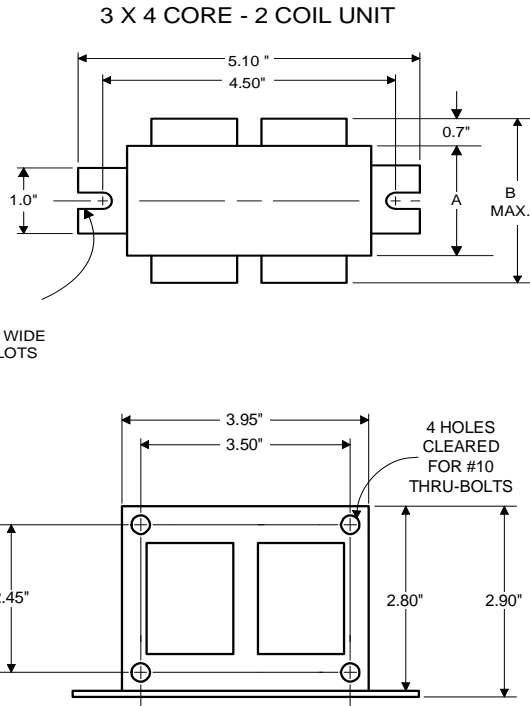

INPUT VOLTS	480				
CIRCUIT TYPE	CWA				
POWER FACTOR (min)	90%				
REGULATION					
Line Volts	±10%				
Lamp Watts	±8%				
LINE CURRENT (Amps)					
Operating.....	0.65				
Open Circuit.....	0.65				
Starting.....	0.30				
UL TEMPERATURE RATINGS					
Insulation Class	H(180°C)				
Coil Temperature Code	1029				
MIN. AMBIENT STARTING TEMP.	-20°F or -30°C				
NOM. OPEN CIRCUIT VOLTAGE	300				
INPUT VOLTAGE AT LAMP DROPOUT.....	240				
INPUT WATTS	298				
RECOMMENDED FUSE (Amps).....	2				
CORE and COIL					
Dimension (A)	3.00				
Dimension (B)	4.20				
Weight (lbs.)	9				
Lead Lengths	12"				
CAPACITOR REQUIREMENT					
Microfarads	15.0				
Volts (min.)	400				
Fault Current Withstand (amps)					
60 Hz TEST PROCEDURES (Refer to Advance Test Procedure for HID Ballasts - Form 1270)					
High Potential Test (Volts)					
1 minute	2000				
2 seconds	2500				
Open Circuit Voltage Test (Volts)	270-330				
Short-Circuit Current Test (Amps)					
Secondary Current	2.00-3.00				
Input Current.....	0.25-0.35	-	-	-	-

Capacitor: 7C150P40-R

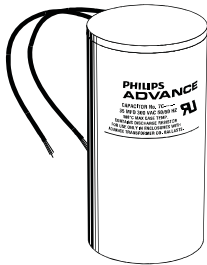

Capacitance: 15  
Dia/Oval Dim: 1.75  
Height: 3.75  
Temp Rating: 105°C

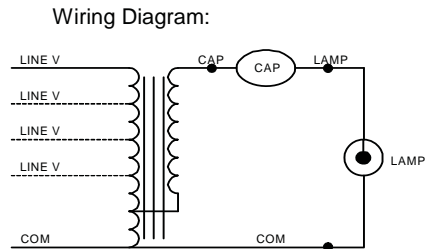

Fig. A

**Ordering Information**

Order Suffix	Description

Ignitor: NA

NA

This ballast does not require the use of an ignitor.

Data is based upon tests performed by Philips Lighting Electronic N.A. in a controlled environment and representative of relative performance. Actual performance can vary depending on operating conditions. Specifications are subject to change without notice.

**Philips Lighting Electronic N.A.**

10275 West Higgins Road · Rosemont, IL 60018 · Tel:800-322-2086 Fax:888-432-1882  
Customer Support/ Technical Service:800-372-3331 · OEM Support: 866-915-5886

08/04/09