

The RS Series combines performance and dependability into a rugged 20 gauge enclosure.

**FEATURES**

- Enclosure constructed of rugged 20 gauge steel
- Available in 6 or 12 Volt with wattages ranging from 25-150 Watts with knockouts for side mounted heads allowing for up to four lamp heads per unit
- Standard with REN1 or REN2 LED lamp heads
- Remote capable
- Charge rate/power "ON" LED indicator light with test button
- AC lockout for ease of installation and installer protection
- Low voltage disconnect eliminates deep discharge
- Brownout, short circuit and voltage surge protection
- Maintenance-free lead calcium or NiMH battery
- UL Listed 90 minute emergency run time
- Optional Guardian Self-test/Self-diagnostics (G2) available
- Optional time delay (TD) feature available
- Standard finish: Black or White
- 120/277V dual primary, 60Hz input
- Optional 220V 50HZ, transformer

Model: \_\_\_\_\_ Date: \_\_\_\_\_  
 Accessories: \_\_\_\_\_  
 Job Name: \_\_\_\_\_ Type: \_\_\_\_\_



Shown with REN2 LED Lamps

**WARRANTY**

Any component that fails due to a manufacturing defect is guaranteed for five years with a separate five year pro-rated warranty on the battery. The warranty does not cover physical damage, abuse or instances of uncontrollable natural forces. See the full Exitronix warranty document for detailed information.



**ORDERING INFORMATION Example: RS6-25-T0609-2-W-G2**

Series	Wattage	Lamp Heads <sup>1</sup>	# Of Lamp Heads	Finish	Options (Factory Installed)
RS6 = 6 Volt Lead Calcium	<b>6 Volt, Lead Calcium</b>	<b>6 or 12 Volt Renegade LED</b>	0 = No Lamps	B = Black	220V <sup>2</sup> = 220VAC 50Hz
RS6NM = 6 Volt NiMH	25 = 25 Watts	REN1 = PAR 18 3.6 Watt LED	2 = 2 Lamp Heads	W = White	G2 = Self-test/Self-diagnostics
RS12 = 12 Volt Lead Calcium	36 = 36 Watts	REN2 = PAR 36 3.6 Watt LED	4 = 4 Lamp Heads		LC = 3' Line Cord
RS12NM = 12 Volt NiMH	50 = 50 Watts	<b>6 Volt Tungsten Wedge Base</b>			TD <sup>3</sup> = Time Delay 120/277VAC
	100 = 100 Watts	T0609 = 9 Watt			
	<b>6 Volt, NiMH</b>	<b>6 Volt Tungsten Sealed Beam</b>			<b>Accessories<sup>4</sup> (Field Installed)</b>
	40 = 40 Watts	R0608 = 8 Watt			WG-A = Wire Guard (Back Mount)
	<b>12 Volt, Lead Calcium</b>	R0618 = 18 Watt			XG-PS = Poly Guard (Back Mount)
	50 = 50 Watts	R0625 = 25 Watt			
	100 = 100 Watts	<b>12 Volt Tungsten Wedge Base</b>			
	150 = 150 Watts	T1209 = 9 Watt			
	<b>12 Volt, NiMH</b>	T1212 = 12 Watt			
	50 = 50 Watts	T1218 = 18 Watt			
		<b>12 Volt Tungsten Sealed Beam</b>			<b>Notes</b>
		R1212 = 12 Watt			<sup>1</sup> Alternate lamp heads are available, consult factory
		R1218 = 18 Watt			<sup>2</sup> Up to 50 Watts only
		R1225 = 25 Watt			<sup>3</sup> Not available on units with G2 option
					<sup>4</sup> Order as separate line item

**T0609-2-W EM BUG-EYE**

## CONSTRUCTION

The RS Series is die-formed 20 gauge steel housing with epoxy powder coat finish. White finish is standard. Universal J-box mounting pattern and keyhole slots provided for simple installation. Knockouts are provided on top, back, and sides for easy wire entry. Can also be shelf mounted – ordered separately.

## ILLUMINATION

Fully adjustable, attractive lamp heads allow for maximum light to be delivered to the path of egress. Up to four lamp heads may be installed on each emergency unit. Emergency lights vary – see ordering information for details. The RS Series includes standard RENEGADE lamps – 3.6 Watts LED per head.

## ELECTRICAL

### Input

Dual-voltage input 120 or 277VAC @ 60Hz.

### Sealed Lead Calcium Battery

Exitronix sealed lead calcium batteries are maintenance-free with a life expectancy of five years. Sealed lead calcium batteries provide a relatively large power-to-weight ratio making them ideal for emergency applications. Lead calcium batteries perform optimally in temperatures ranging from 59°F to 104°F (15°C to 40°C).

### Nickel Metal Hydride – NiMH (RS6NM, RS12NM)

Exitronix nickel metal hydride batteries are maintenance-free with a life expectancy of 15 years. NiMH batteries perform optimally in temperatures ranging from 32°F to 104°F (0°C to 40°C). NiMH batteries are more environmentally-friendly than traditional NiCad or lead calcium alternatives as they contain no cadmium or lead.

### Emergency

The RS Series exit will operate for a minimum of 90 minutes during a loss of power with a 24 hour maximum recharge time for the battery.

### Brownout Circuit

Brownout circuit monitors the line voltage, as the line voltage sags and can no longer illuminate the exit sign to meet UL 924 visibility test, the emergency circuit will turn on to supply a portion or all the power to illuminate the sign for 90 minutes until the line voltage is restored.

### Low Voltage Disconnect

Low Voltage Disconnect (LVD) measures the battery terminal voltage. The LVD continuously monitors the battery terminal voltage and if it should fall below a preset voltage threshold, the LVD will disconnect the load. When the battery is recharging and voltage is raised above another preset voltage threshold, the load is automatically reconnected.

### Solid-State Transfer

The circuit features solid-state switching for emergency lamps, eliminating concerns of damaged contact or mechanical failures associated with relays. The switching circuit detects a loss of line voltage and automatically switches to emergency mode.

### Overload and Short-Circuit Protection

The overload monitoring system is a solid state circuit which monitors the lamp load and disconnects from the battery shall an overload or short circuit occur. The overload current protection eliminates the need for fuses or circuit breakers for the DC load.

### Test Button

The test button is easy to locate and provides manual verification of the transfer circuit and emergency lamps.

## INSTALLATION

A universal mounting pattern and rear keyhole slots are provided for wall mounting.

### Guardian Self-test/Self-diagnostics (Option: G2)

The Guardian circuit continuously monitors the operating condition of the AC power, battery supply voltage, emergency lamp continuity and charging circuit.

The purpose of this option is to provide visual signaling in response to a fault at the battery and/or battery charger. If a failure is detected, visual status will occur immediately via an LED indicator. The code will display until the fault is corrected.

The Guardian circuit also monitors the transfer circuit as well as performing automatic code compliant testing. The Guardian circuit will perform a 90 minute self-test every 180 days. A five minute manual test can be initiated by the user.

### Time Delay (Option: TD)

The purpose of this feature is to allow additional time for “normally on” fixtures to return to full brightness prior to extinguishing the supplemental light from the emergency fixtures.

## CONFORMANCE TO CODES & STANDARDS

The RS Series is UL listed and meets or exceeds the following: UL 924, NEC requirements and NFPA 101.

## DIMENSIONS

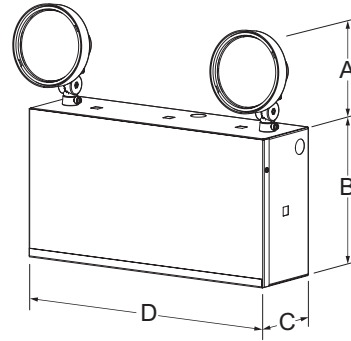

	25-40W	50-60W	100W	150W
A	6.0"	6.0"	6.0"	6.0"
B	5.3"	8.0"	8.5"	8.5"
C	2.9"	3.0"	4.6"	4.6"
D	11.6"	13.3"	13.3"	16.1"