

JUNO**TRAC-MASTER**[®]

Project: _____

Fixture Type: _____

Location: _____

Contact/Phone: _____

Current Limiting Feeds For T Series and TU Series Trac Systems

PRODUCT DESCRIPTION

Juno Trac-Master Current Limiting Feeds provide a simple solution for complying with stringent energy codes like ASHRAE 90.1 and California Title 24. Installed at every trac lighting feed location, these feeds employ supplementary current limiting circuit breakers which are designed to limit available wattage to lighting circuits to only that necessary to meet the lighting design criteria. Rather than lighting loads being calculated by the greater of maximum fixture wattage ratings or an arbitrary watts-per-foot multiplier, the Trac-Master Current Limiting Feeds enable calculations to instead be made based on the rating of the supplementary breaker(s) installed in the feeds. Because they limit a circuit, not the lighting equipment itself, the Trac-Master Current Limiting Feeds provide maximum flexibility to accommodate frequent lighting design modifications and layout changes, especially typical for retail spaces.



PRODUCT SPECIFICATIONS

Features Designed to be installed at every trac feed location, in place of a standard non-limiting feed • In-line feeds can be used to feed trac as one electrical circuit in both directions or as two separate circuits using two current limiters • Feed connector and current limiting circuit breaker are specified and ordered separately for maximum configuration flexibility • Not intended to be used as a primary circuit protector.

Mini End Feed Construction Single circuit trac compatibility only • Heavy-duty 16 gauge (0.060 thick) die formed galvanized steel mounting plate • Mounting plate slides into trac channel to prevent sagging in suspended applications • Surface mounting only – not intended to be installed over a j-box • T-bar compatible only when installed off-grid and fed directly • One 7/8" knockout for direct electrical feed connections • Includes ground terminal attachment screw • Injection molded polycarbonate cover attaches to mounting plate using tamper-resistant screws (screwdriver bit supplied with each mini end feed) • Mini end feed connector is permanently attached to trac using one-way screw • Also available in reverse polarity configuration.

End Feed Construction Heavy-duty 14 gauge (0.075 thick) die formed galvanized steel mounting plate • Surface or j-box mounting • T-bar compatible when fed directly • Mounting holes provided for j-box attachment • Center knockout enables feeding from j-box for simple wiring termination • Two 7/8" knockouts for direct electrical feed connections • Includes ground terminal attachment screw • Injection molded polycarbonate cover with tearout for 2-breaker installations • Cover attaches to mounting plate using tamper-resistant screws (screwdriver bit supplied each mini end feed) • Feed connector is permanently attached to trac using one-way screw.

Finish Available in white, black or silver finishes • Supplementary current limiting circuit breakers are ordered separately and can be specified in corresponding finishes to match feed connector.

Supplementary Current Limiting Circuit Breakers Miniature single pole supplementary current limiters limit the current (wattage) that can be consumed on the trac section being fed • Utilizes hydraulic magnetic technology which provides accurate and reliable circuit protection even when exposed to extremely hot and/or cold application environments • Rated for 120VAC, 60Hz operation • Available in individual amperage ratings of 0.5A, 1A, 2A, 3A, 4A, 5A, 6A, 7A, 8A, 9A, 10A, 12A and 14A, selected based on actual lighting loads • Can be operated continuously at rated current • Specially designed to prevent nuisance tripping • Easily snaps into mounting plate without the use of tools • Leads wires provided for simplified installation • ON/OFF indication clearly identifies breaker status • Easily resettable in the event of an overcurrent situation • UL 1077, CSA 22.2 approved.

Labels UL and cUL Listed • Approved by the California Energy Commission to meet the requirements of Title 24 • Complies with ASHRAE 90.1 and IECC Section 805.5.1.4 for trac current limiting.

Warranty 5-year limited warranty. Complete warranty terms located at: www.acuitybrands.com/CustomerResources/Terms_and_conditions.aspx.

Specifications subject to change without notice.



Current Limiting Feeds
For T Series and TU Series Trac Systems

ORDERING INFORMATION

Electrical feeds are chosen based on application (end or in-line, 1-circuit trac or 2-circuit trac). Supplementary current limiters are chosen separately based on total wattage to be applied to the trac circuit. Feeds and current limiters are supplied separately and easily assembled by the installer.

Current Limiting Electrical Feeds

Catalog Number	Description	Trac Type	Finish
TCLFM11 BL	Mini End Feed	1-Circuit, T Series	Black
TCLFM11 WH	Mini End Feed	1-Circuit, T Series	White
TCLFM11 SL	Mini End Feed	1-Circuit, T Series	Silver
TCLFM11 RP BL	Mini End Feed	1-Circuit, T Series	Black
TCLFM11 RP WH	Mini End Feed	1-Circuit, T Series	White
TCLFM11 RP SL	Mini End Feed	1-Circuit, T Series	Silver
TCLF11 BL	End Feed	1-Circuit, T Series	Black
TCLF11 WH	End Feed	1-Circuit, T Series	White
TCLF11 SL	End Feed	1-Circuit, T Series	Silver
TCLF21 BL	In-Line Feed	1-Circuit, T Series	Black
TCLF21 WH	In-Line Feed	1-Circuit, T Series	White
TCLF21 SL	In-Line Feed	1-Circuit, T Series	Silver
TUCLF11 BL	End Feed	2-Circuit, TU Series	Black
TUCLF11 WH	End Feed	2-Circuit, TU Series	White
TUCLF11 SL	End Feed	2-Circuit, TU Series	Silver
TUCLF21 BL	In-Line Feed	2-Circuit, TU Series	Black
TUCLF21 WH	In-Line Feed	2-Circuit, TU Series	White
TUCLF21 SL	In-Line Feed	2-Circuit, TU Series	Silver

Current Limiting Circuit Breakers (order separately)

Catalog Number	Current Limiter	Wattage	Finish
TCLCB 0.5A BLCK	0.5A	60W	Black
TCLCB 0.5A WHT	0.5A	60W	White
TCLCB 1A BLCK	1A	120W	Black
TCLCB 1A WHT	1A	120W	White
TCLCB 2A BLCK	2A	240W	Black
TCLCB 2A WHT	2A	240W	White
TCLCB 3A BLCK	3A	360W	Black
TCLCB 3A WHT	3A	360W	White
TCLCB 4A BLCK	4A	480W	Black
TCLCB 4A WHT	4A	480W	White
TCLCB 5A BLCK	5A	600W	Black
TCLCB 5A WHT	5A	600W	White
TCLCB 6A BLCK	6A	720W	Black
TCLCB 6A WHT	6A	720W	White
TCLCB 7A BLCK	7A	840W	Black
TCLCB 7A WHT	7A	840W	White
TCLCB 8A BLCK	8A	960W	Black
TCLCB 8A WHT	8A	960W	White
TCLCB 9A BLCK	9A	1080W	Black
TCLCB 9A WHT	9A	1080W	White
TCLCB 10A BLCK	10A	1200W	Black
TCLCB 10A WHT	10A	1200W	White
TCLCB 12A BLCK	12A	1440W	Black
TCLCB 12A WHT	12A	1440W	White
TCLCB 14A BLCK	14A	1680W	Black
TCLCB 14A WHT	14A	1680W	White

DIMENSIONS

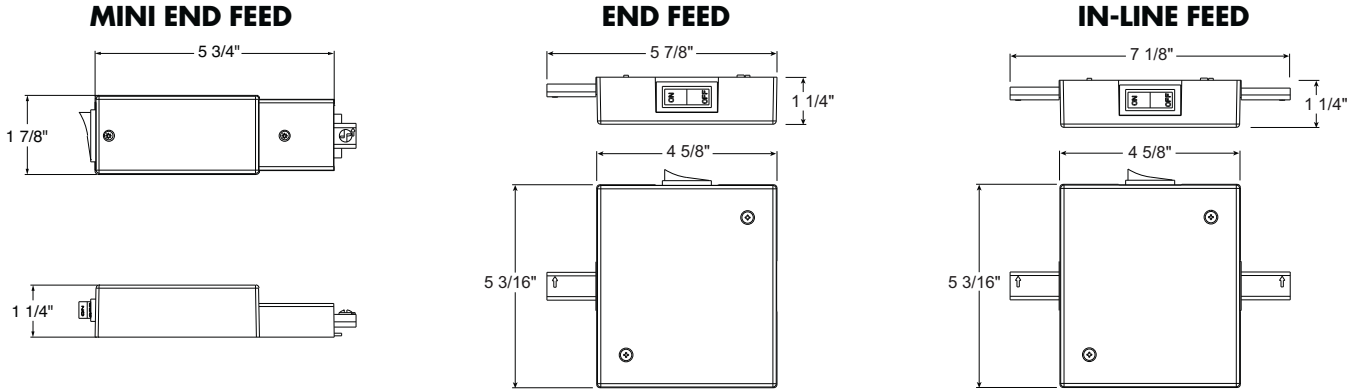

APPLICATION

Energy codes typically calculate trac lighting loads based on linear feet of installed trac. Some codes use an arbitrary multiplier as low as 30 watts/foot while others use a multiplier as high as 70 watts/foot. When using the energy efficient lighting technologies available today, the connected load is typically much less than the per-foot multipliers used by most energy codes. This penalizes lighting designs that employ trac lighting and wastes available lighting watts that could be used more effectively.

Below is a typical trac lighting example. The Standard Layout consists of 100' of single circuit trac (4 circuits x 25' each) with 32 LED trac heads, each consuming 24W, for a total connected load of 768W. The scenario with the *Trac-Master* Current Limiting Feeds uses the original 100' of single circuit trac, with each 25' trac section monitored by a 2-Amp supplementary current limiter that is closely matched to the actual connected load of 768W plus a small buffer. This significantly reduces the calculated watts per the energy codes.

1. Standard Layout without Trac-Master Current Limiting Feeds

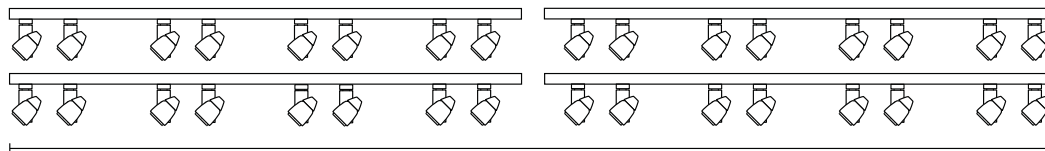

Trac length determines wattage calculation

100 ft of track = **4500W***

*Based on 45W/ft multiplier of California Title 24

Trac-Master Current Limiting Feeds install between the branch circuit breaker and the trac lighting, solving the energy code calculation discrepancy, making the wattage calculation independent of trac length.

3. Standard Layout with Trac-Master Current Limiting Feeds

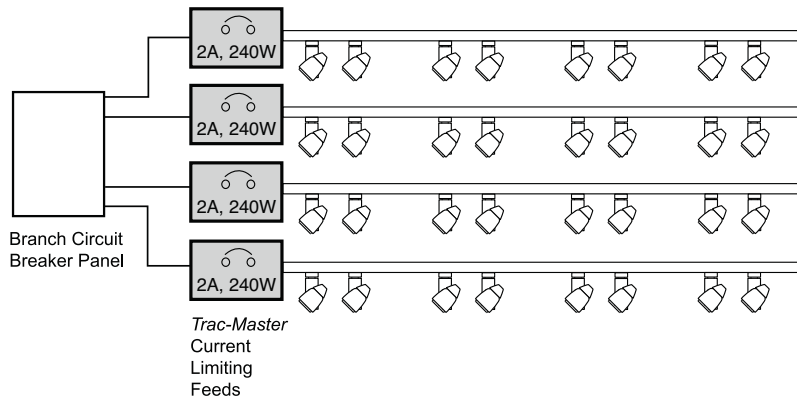

Same 100 ft. of trac: **2A @ 120V = 240W (x4 circuits)**

960W total